

FIELD CUT TOP OF DOWNSPOUT TO FIT BEVEL OF GUTTER. USE DOWNSPOUT AS TEMPLATE TO MARK BOTTOM OF GUTTER. DRILL 3/8" HOLE IN GUTTER AND FIELD CUT AS SHOWN. BEND TABS DOWN AND ATTACH THE DOWNSPOUTS WITH (4) TRIM FASTENERS.

DOWNSPOUT ATTACHMENT

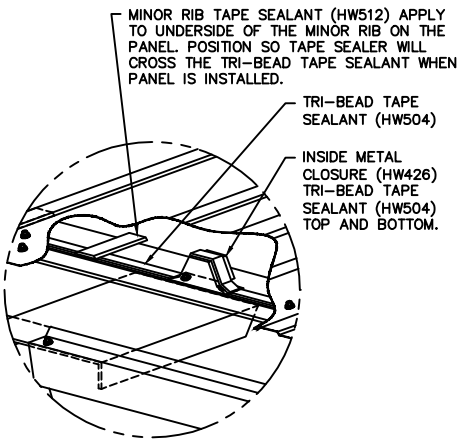

DETAIL "A"

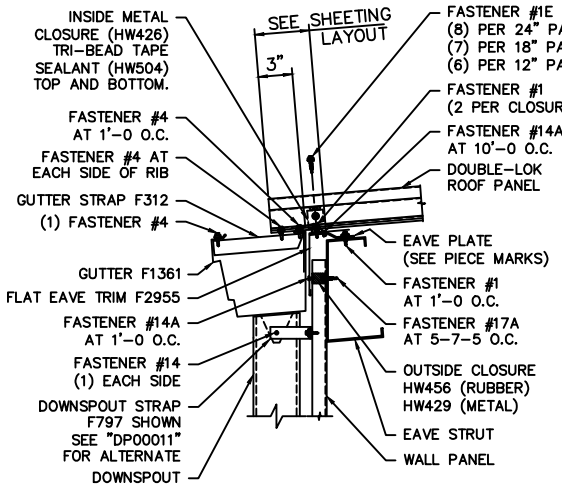

STANDARD SECTION AT PBR WALL WITH FLAT EAVE TRIM

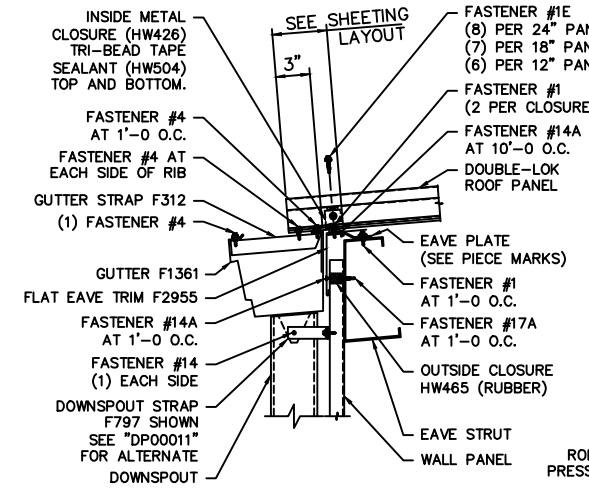

STANDARD SECTION AT AVP WALL WITH FLAT EAVE TRIM

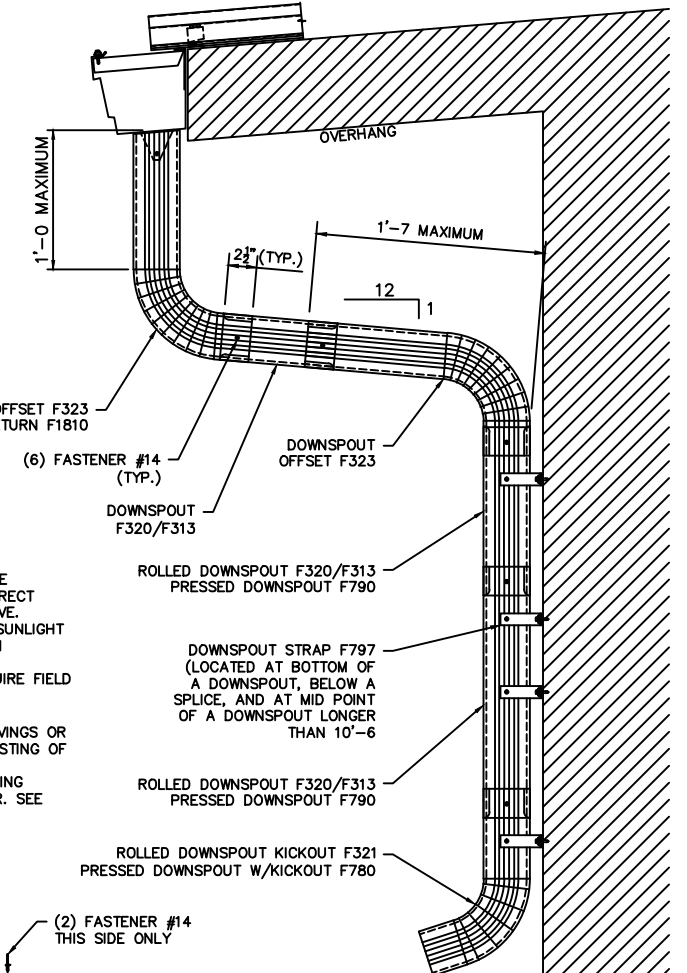

STANDARD DOWNSPOUT DETAIL AT CANOPY (ROLL FORMED SHOWN)

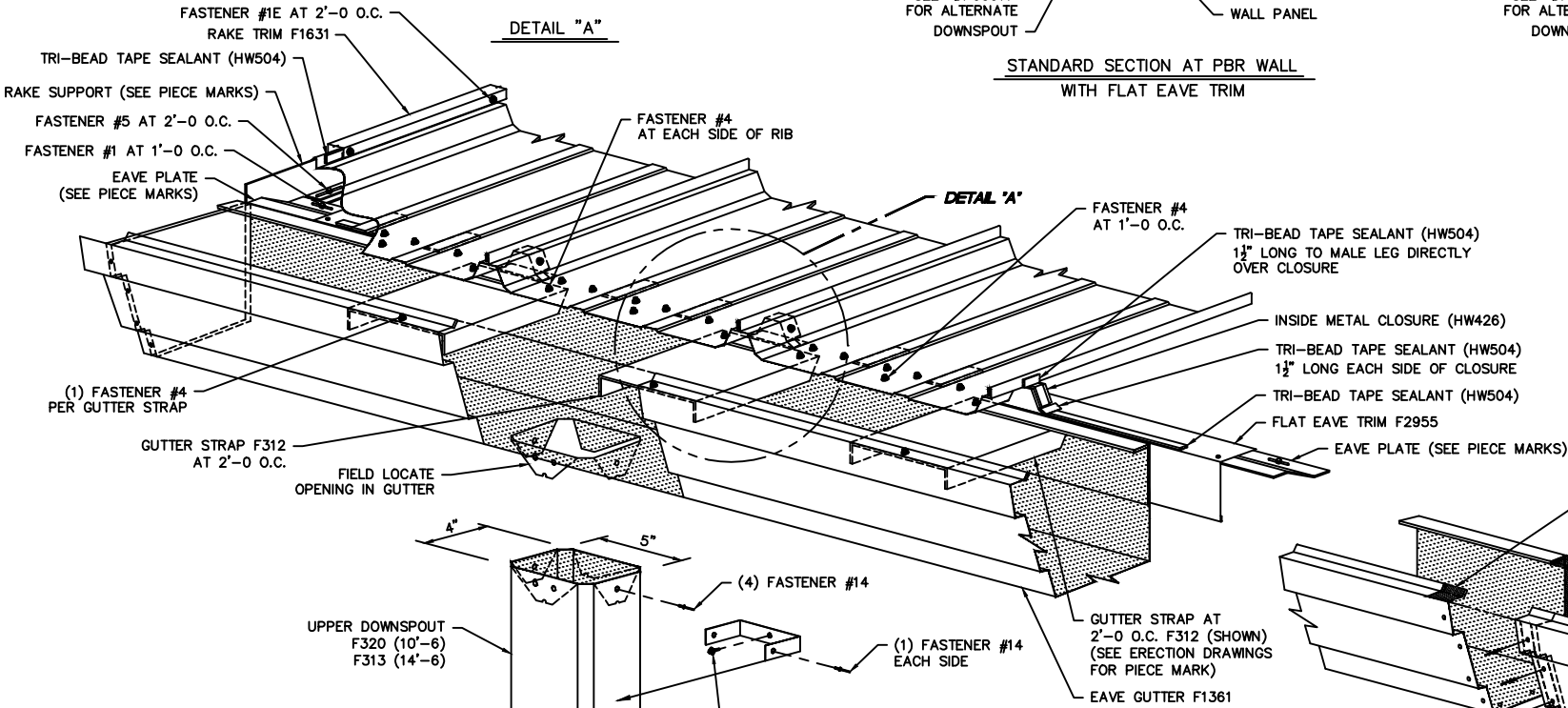

PIECE MARKS

- EAVE PLATE PIECE MARKS**
 EAVE STRUT TO PURLIN SPACE > 48"
 LOW - NONE REQUIRED
 HIGH - HW7616
 HIGH THERMAL - HW7661
- EAVE PLATE PIECE MARKS**
 EAVE STRUT TO PURLIN SPACE < 48"
 LOW - HW7600 (SHOWN)
 HIGH - HW7654
 HIGH THERMAL - HW7661
- RAKE SUPPORT ANGLE PIECE MARKS**
 LOW - HW7710 (SHOWN)
 HIGH - HW7720
 HIGH THERMAL - HW7664
 UTILITY - HW7722

- NOTES:**
- 1.) PERIMETER TRIM AND GUTTERS MAY BE COATED WITH A REMOVABLE PROTECTIVE FILM. AFTER PROLONGED PERIODS OF EXPOSURE TO DIRECT SUNLIGHT THE FILM MAY BECOME BRITTLE AND DIFFICULT TO REMOVE.
 - 2.) TO AVOID SUCH DIFFICULTIES, COVER THESE PARTS FROM DIRECT SUNLIGHT AT THE STORAGE SITE AND JOBSITE. REMOVE THE PROTECTIVE FILM DURING ERECTION OR IMMEDIATELY AFTER.
 - 3.) TRIM PARTS ARE PROVIDED IN STANDARD LENGTHS AND MAY REQUIRE FIELD CUTTING TO LENGTH. (NOTE, THE REMAINDER MAY BE REQUIRED AT DIFFERENT LOCATION.)
 - 4.) ROOF AND WALL PANELS SHOULD BE CLEANED OF ANY DRILL SHAVINGS OR FIELD CUTTING FILINGS AT THE END OF EACH DAY TO PREVENT RUSTING OF THESE PARTICLES.
 - 5.) DOWNSPOUTS TO BE FIELD CUT TO LENGTH IF REQUIRED. WHEN USING REMAINDER WITHOUT SWEDGE FOR LAP, FIELD NOTCH EACH CORNER. SEE DOWNSPOUT NOTCH DETAIL.

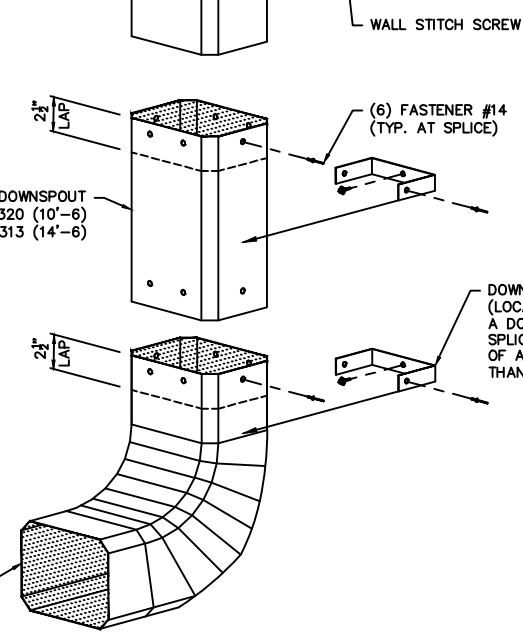

STANDARD DOWNSPOUT

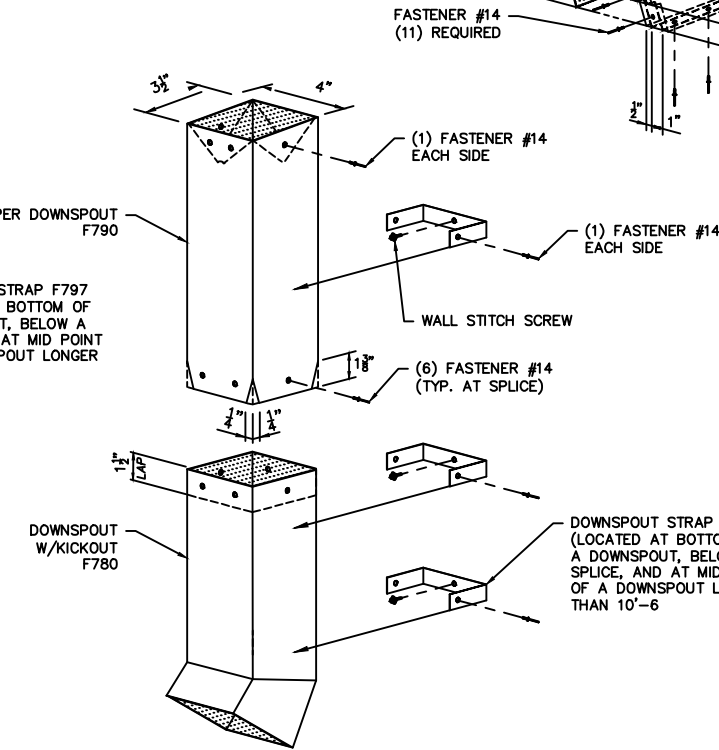

ALTERNATE DOWNSPOUT

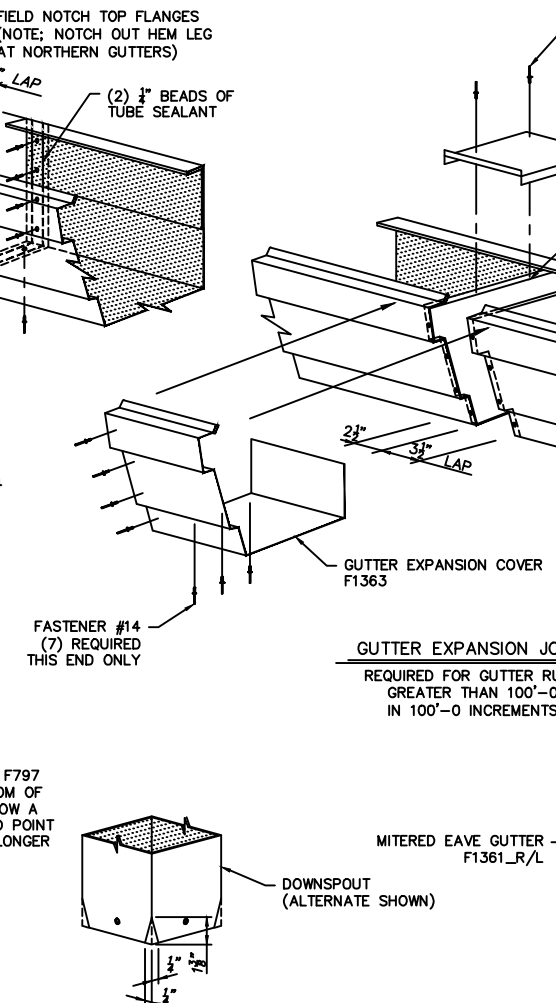

DOWNSPOUT NOTCH DETAIL

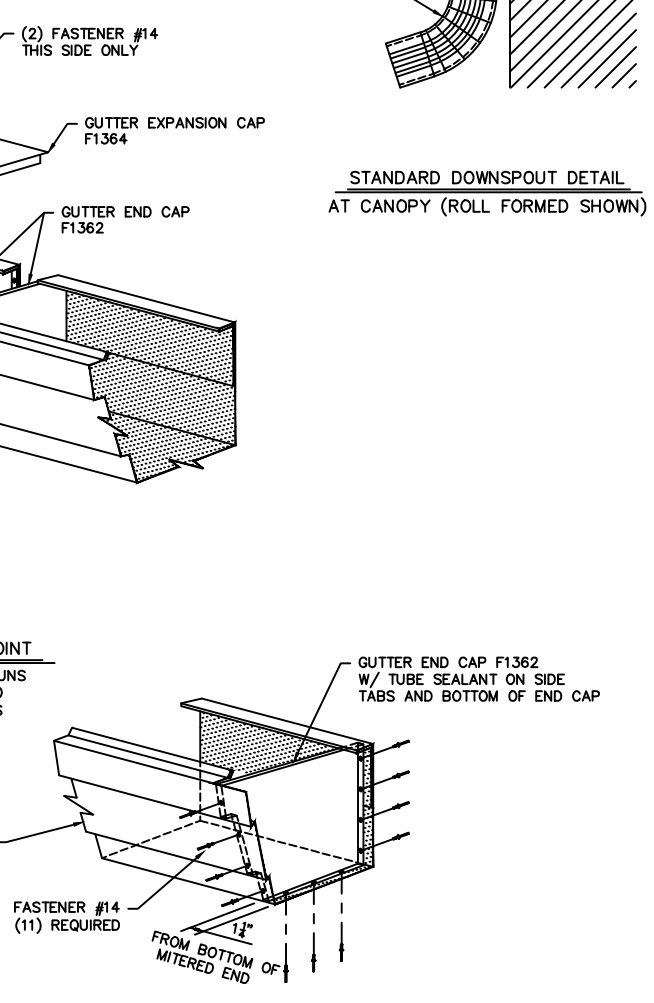

GUTTER END CLOSURE