

Longitudinal Partition Jamb Connection - High Side Sheeted

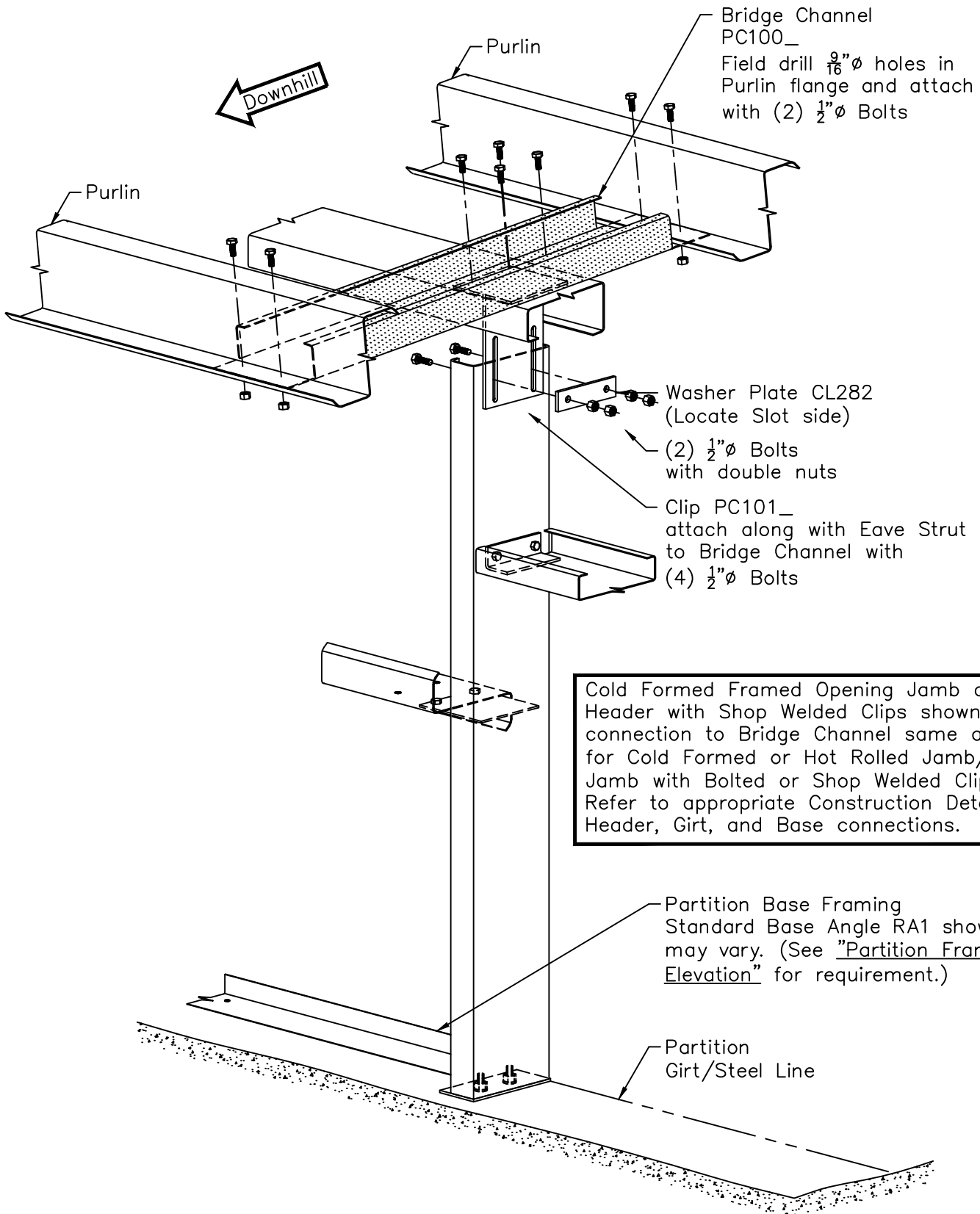

Zee Girts shown, attachment similar for Cee or Zee Girt with outer flange toed up.